

THE INFORMATION CONTAINED IN THIS DRAWING IS THE SOLE PROPERTY OF RADIAN HEATSINKS AND ANY REPRODUCTION IN PART OR IN WHOLE IS STRICTLY PROHIBITED WITHOUT THE WRITTEN PERMISSION OF RADIAN HEATSINKS.

EXPLODED VIEW

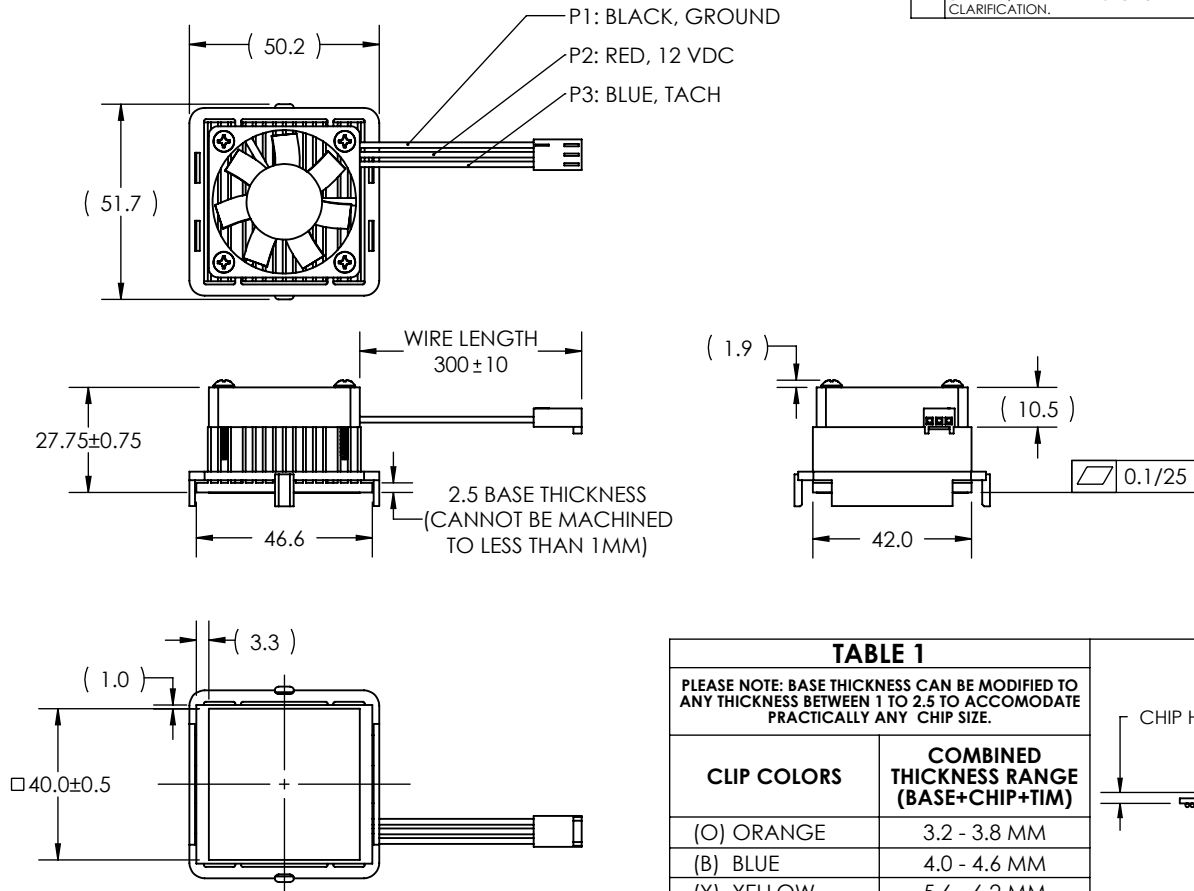
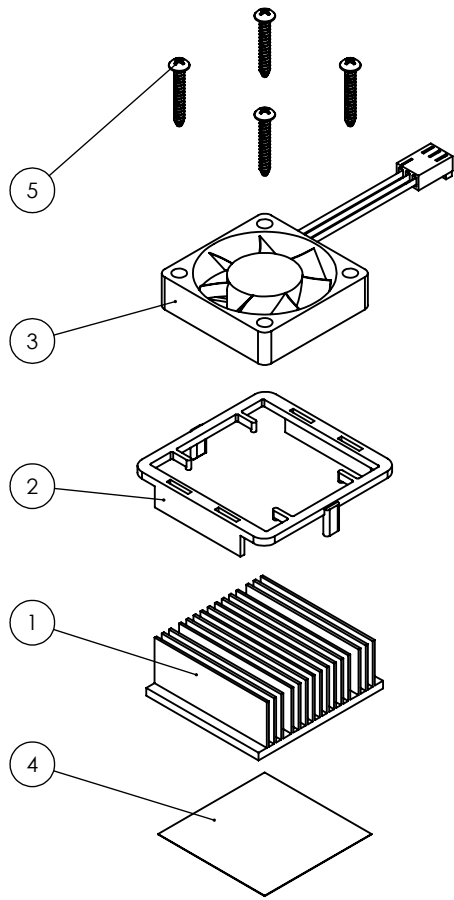

REV	DESCRIPTION	APPROVED	DATE
A	INITIAL RELEASE	AS	6/7/2017
B	UPDATED PER ECN1710231: HEATSINK WAS UPDATED, ADDED TABLES FOR ORDERING CLARIFICATION.	AS	10/23/2017

- NOTES:
- CUSTOMER TO SPECIFY COMPLETE PART NUMBER. SEE "EXAMPLE PART NUMBERS" TABLE FOR PART NUMBER CONVENTIONS.
 - IF BASE THICKNESS IS MODIFIED, RE-ANODIZATION NOT REQUIRED.
 - FAN AND SCREWS ARE SHOWN AS ILLUSTRATION ONLY; ACTUAL PARTS MAY LOOK DIFFERENT.
 - PART TO BE RoHS COMPLIANT.

TABLE 1		CHIP HEIGHT EXCLUDES BALL SIZE
CLIP COLORS	COMBINED THICKNESS RANGE (BASE+CHIP+TIM)	
(O) ORANGE	3.2 - 3.8 MM	
(B) BLUE	4.0 - 4.6 MM	
(Y) YELLOW	5.6 - 6.2 MM	

EXAMPLE PART NUMBERS		
PART NUMBER	DESCRIPTION	CHIP THICKNESS RANGE
* FA47.5/2.2+Y+T725	MODIFIED BASE THICKNESS TO 2.2MM. HAS A YELLOW CLIP AND T725 TIM	3.3 - 3.9 MM
FA47.5+3M8815	HEATSINK AND FAN WITH 3M8815 THERMAL TAPE. NO CLIP REQUIRED.	ANY CHIP SIZE

*WHEN A SLASH AND NUMBER IS ADDED AFTER FA47.5, THE NUMBER SPECIFIES NEW BASE THICKNESS.

ITEM NO.	PART NUMBER	DESCRIPTION	QTY.
1	HS10000	HEATSINK, PLATE FIN, 42 X 46.6 X 17.25MM	1
2	BCP50-09(47.5)COLOR (SEE TABLE 1)	EZ SNAP CLIP, 47.5MM BGA	1
3	HS8072	40X40X10MM FAN, 12 VDC WITH 3 PIN CONNECTOR	1
4	OPTIONAL	CHOMERICS T725 PAD 40X40 MM OR FULL COVERAGE	1
5	4N75PPBZB	#4 X 3/4 PHIL PAN TYPE B SMS BLK (RoHS)	4

MATERIAL	APPROVALS	DATE	RADIAN HEATSINKS RADIAN THERMAL PRODUCTS, INC. 2160 WALSH AVE SANTA CLARA, CA 95050
FINISH	DRAWN	11/16/2017	
UNLESS OTHERWISE SPECIFIED DIMENSIONS ARE IN MM TOLERANCES ARE: 1 PLACE DECIMALS: ± 0.25 2 PLACE DECIMALS: ± 0.10 ANGLES: ± 1°	CHECKED	11/16/2017	
	ASHARMA MFG ENG		
THIRD ANGLE PROJECTION	QUAL ENG.		47.5MM BGA FANSINK SIZE DWG. NO. FA47.5
	SHEET 1 OF 1		REV. B