

THE INFORMATION CONTAINED IN THIS DRAWING IS THE SOLE PROPERTY OF RADIAN HEAT SINKS AND ANY REPRODUCTION IN PART OR IN WHOLE IS STRICTLY PROHIBITED WITHOUT THE WRITTEN PERMISSION OF RADIAN HEATSINKS.

REVISIONS			
REV.	DESCRIPTION	DATE	APPROVED
A	INITIAL DESIGN	11/2/05	FWANG
B	REDESIGNED	1/13/06	FWANG
C	CHANGED SCREW P/N	4/20/06	FWANG
D	ECN#801101: CHANGED SCREWS	1/10/08	FWANG
E	PER ECN#803141	03/21/08	AREDDY
F	PER ECN#806241	07/08/08	FWANG
G	ECN#212121: CHANGED SCREW	12/12/12	SCAO
H	ECN1506111: REPLACED HS8075 WITH HS8108 AND CHANGED SCREW	6/11/15	TS
J	ECN1507012: EXCHANGED PIN P1 WITH PIN P3	7/1/15	SC
K	ECN1606011: UPDATED INCORRECT PIN LABELS	6/2/16	AS

EXPLODED VIEW

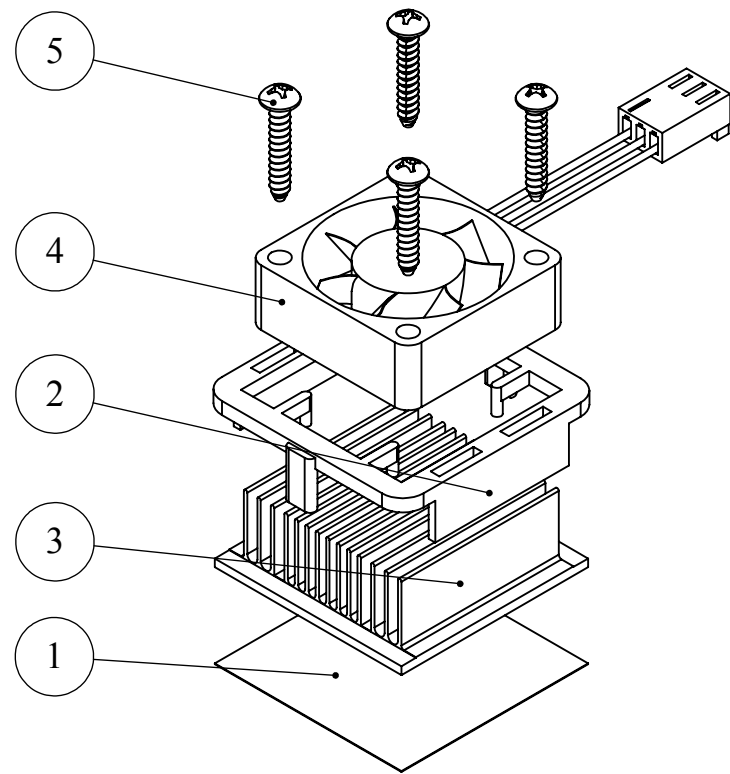

P1: BLACK, GND
 P2: RED, 5 V DC
 P3: WHITE, TACH
 WIRE LENGTH
 300 ± 10MM

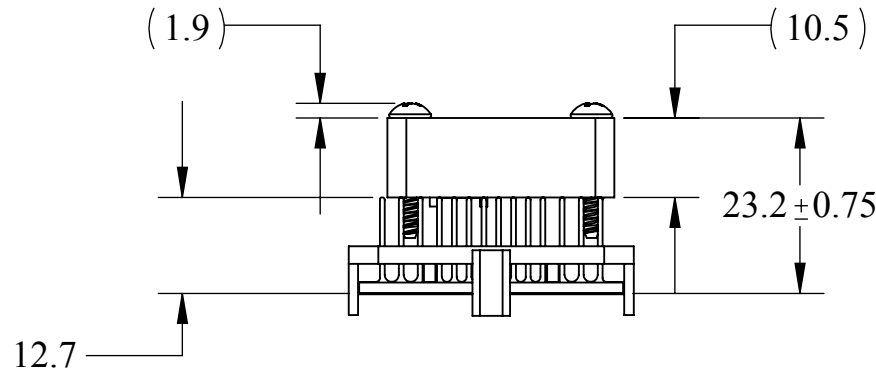
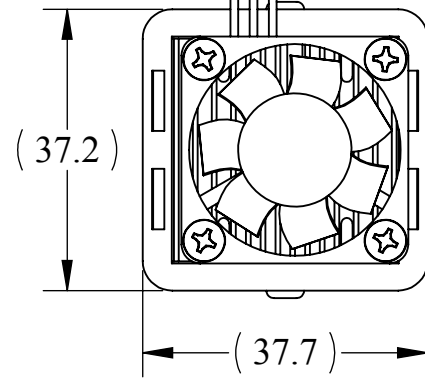

NOTES:

1. DRAWINGS OF FAN AND SCREWS ARE FOR ILLUSTRATION ONLY; ACTUAL PARTS MAY LOOK SLIGHTLY DIFFERENT.
2. CUSTOMER TO SPECIFY CLIP AND PAD TYPES.
3. RECOMMENDED MATING CONNECTOR HEADER MOLEX 22-23-2031

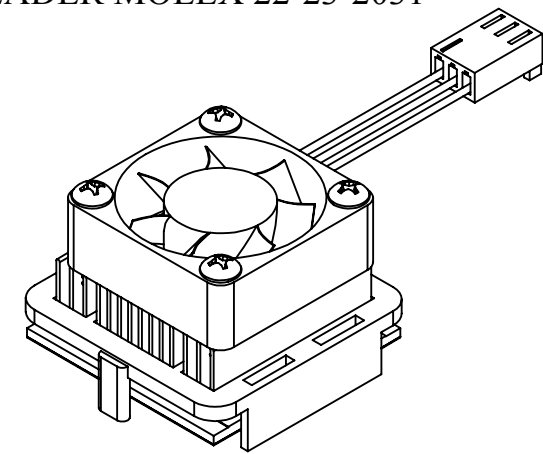

COMPLETE PART NUMBER WITH OPTIONS

BASE	SUFFIX 1	DESCRIPTION	SUFFIX 2	DESCRIPTION	SUFFIX 3	DESCRIPTION
FB35	+K25	K25 EZ-SNAP CLIP	B	RETENTION PEGS ON CLIP IN EXTRUSION DIRECTION	+T710	PHASE CHANGE PAD
	+K35	K35 EZ-SNAP CLIP			+T405R	TAPE FOR METAL PACKAGES
	+K51	BCP37-09(35) ORANGE CLIP			+T412	TAPE FOR METAL PACKAGES
	+K52	BCP37-09(35) BLUE CLIP			+T411	TAPE FOR PLASTIC PACKAGES
	+K53	BCP37-09(35) YELLOW CLIP			+T725	PHASE CHANGE PAD
	+K29	K29 EZ-SNAP CLIP				

EXAMPLE PART NUMBER: FB35+K52B+T710

ITEM #	PART #	DESCRIPTION	QTY
1	P3805	CHOMERICS T710 PAD 35X35 MM	1
2	BCP37-09(35)BU	35 MM EZ-SNAP CLIP BLUE	1
3	HS1807EB	35 MM BGA HEAT SINK	1
4	HS8108	30MM 5V DC FAN WITH CONNECTOR	1
5	4N62PPBZB	#4 X 5/8 PHIL PAN TYPE B SMS BLK (RoHS)	4

UNLESS OTHERWISE SPECIFIED DIMENSIONS ARE IN MM TOLERANCES ARE: DECIMALS ANGLES X. ±.25 ±1° X.X ±.25 X.XX ±.10		CAD GENERATED DRAWING, DO NOT MANUALLY UPDATE		 RADIAN HEATSINKS RADIAN THERMAL PRODUCTS, INC. 2160 WALSH AVE SANTA CLARA, CA 95050	
APPROVALS	DATE	DRAWN		CHECKED	
TLAM	07/07/08	RESP ENG		MFG ENG	
	07/08/08	FINISH		QUAL ENG	
NEXT ASSY	USED ON	DO NOT SCALE DRAWING		SIZE B	DWG. NO. FB35
APPLICATION				REV. K	