

THE INFORMATION CONTAINED IN THIS DRAWING IS THE SOLE PROPERTY OF RADIAN HEATSINKS AND ANY REPRODUCTION IN PART OR IN WHOLE IS STRICTLY PROHIBITED WITHOUT THE WRITTEN PERMISSION OF RADIAN HEATSINKS.

REV	DESCRIPTION	DRAWN	APPROVED	DATE
A	INITIAL RELEASE	KH	JP	1/11/2021
B	ECN2102082: CORRECTION TO PART NUMBERS FOR ITEMS 1 AND 2. CORRECTION TO ITEM 5 DESCRIPTION. CORRECTION TO REF DIMENSION AND EXPLODED VIEW	JP	WR	2/8/2021
C	ECN2110211: CHANGE TO ASSEMBLY SCREWS AND CHANGE TO ASSOCIATED SECTION VIEW	JP	WR	10/21/2021

TABLE 1

PLEASE NOTE: BASE THICKNESS CAN BE MODIFIED TO ANY THICKNESS BETWEEN 1 TO 1.7 TO ACCOMODATE PRACTICALLY ANY CHIP SIZE. CHIP SIZE DOES NOT INCLUDE SOLDER BALLS HEIGHT.

CLIP COLORS	MIN - MAX CHIP THICKNESS
(O) ORANGE	0.9 - 1.4 mm
(B) BLUE	1.5 - 2.0 mm
(Y) YELLOW	2.1 - 2.6 mm

EXAMPLE PART NUMBERS

PART NUMBER	DESCRIPTION	CHIP THICKNESS RANGE
FI37.5/1.4+Y+T725	MODIFIED BASE THICKNESS TO 1.4MM. HAS A YELLOW CLIP AND T725 TIM	2.4 - 2.9 mm
FI37.5+3M8815	HEATSINK AND FAN WITH 3M8815 THERMAL TAPE. NO CLIP REQUIRED.	ANY CHIP SIZE

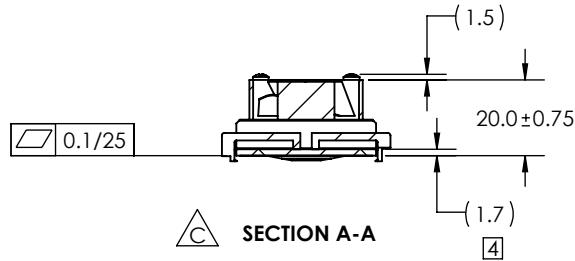
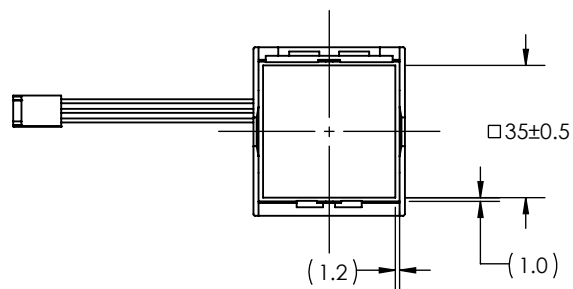
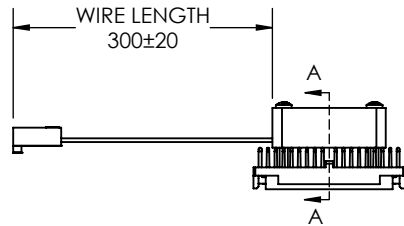
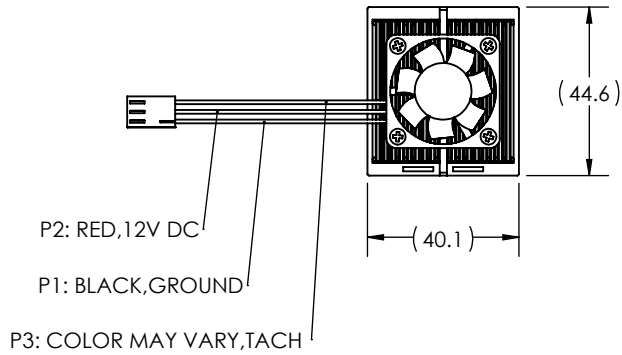

NOTES:

- CUSTOMER TO SPECIFY COMPLETE PART NUMBER. SEE "EXAMPLE PART NUMBERS" TABLE FOR PART NUMBER CONVENTIONS.
- IF BASE THICKNESS IS MODIFIED, RE-ANODIZATION NOT REQUIRED.
- FAN AND SCREWS ARE SHOWN FOR ILLUSTRATION PURPOSE ONLY, ACTUAL PARTS MAY LOOK DIFFERENT.
- DEFAULT BASE THICKNESS. IF MODIFICATION IS REQUIRED, CANNOT BE REDUCED TO LESS THAN 1MM.
- PART TO BE RoHS COMPLIANT.

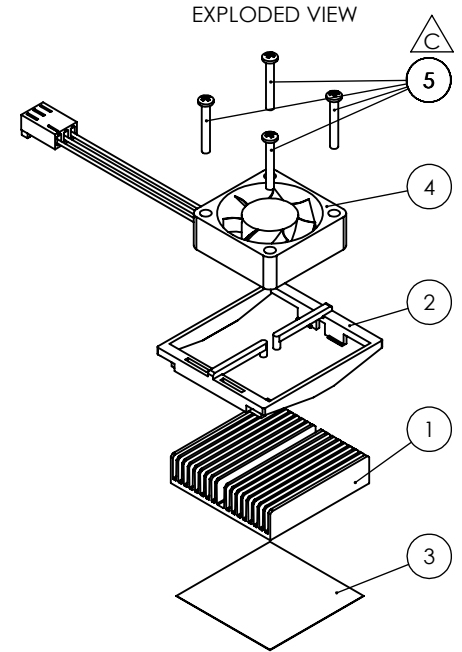

ITEM NO.	PART NUMBER	DESCRIPTION	QTY
1	INL37.5001-10/1.7	37.5mm PLATE FIN HEAT SINK	1
2	BCP4540-08(37.5)COLOR	OPTIONAL 37.5mm LOW PROFILE CLIP	1
3	OPTIONAL	THERMAL PAD 35X35 mm OR FULL COVERAGE	1
4	HS8107	12V 30X30X10 mm DC FAN W/CONNECTOR	1
5	2N62PPBS	#2 X 5/8 STAINLESS STEEL SELF TAPPING SCREW OR EQUIVALENT	4

MATERIAL	APPROVALS	DATE
<del>FINISH</del>	DRAWN KHSIN	7/13/2020
UNLESS OTHERWISE SPECIFIED DIMENSIONS ARE IN mm TOLERANCES ARE: 1 PLACE DECIMALS: ± 0.25 2 PLACE DECIMALS: ± 0.10 ANGLES: ± 1°	CHECKED WRAFAEL	2/8/2021
	MFG ENG	
	QUAL ENG.	
THIRD ANGLE PROJECTION	SHEET 1 OF 1	

**RADIAN HEATSINKS**  
 RADIAN THERMAL PRODUCTS, INC.  
 2160 WALSH AVE  
 SANTA CLARA, CA 95050

**37.5mm BGA FANSINK**

SIZE DWG. NO. FI37.5