

THE INFORMATION CONTAINED IN THIS DRAWING IS THE SOLE PROPERTY OF RADIAN HEATSINKS AND ANY REPRODUCTION IN PART OR IN WHOLE IS STRICTLY PROHIBITED WITHOUT THE WRITTEN PERMISSION OF RADIAN HEATSINKS.

REV	DESCRIPTION OF REVISIONS	APPROVED	DATE
B	NEW RELEASE WITH 12.7 MM HEIGHT	FWANG	7/1/10
C	ECN#007161: REVISED BOM	FWANG	7/16/10

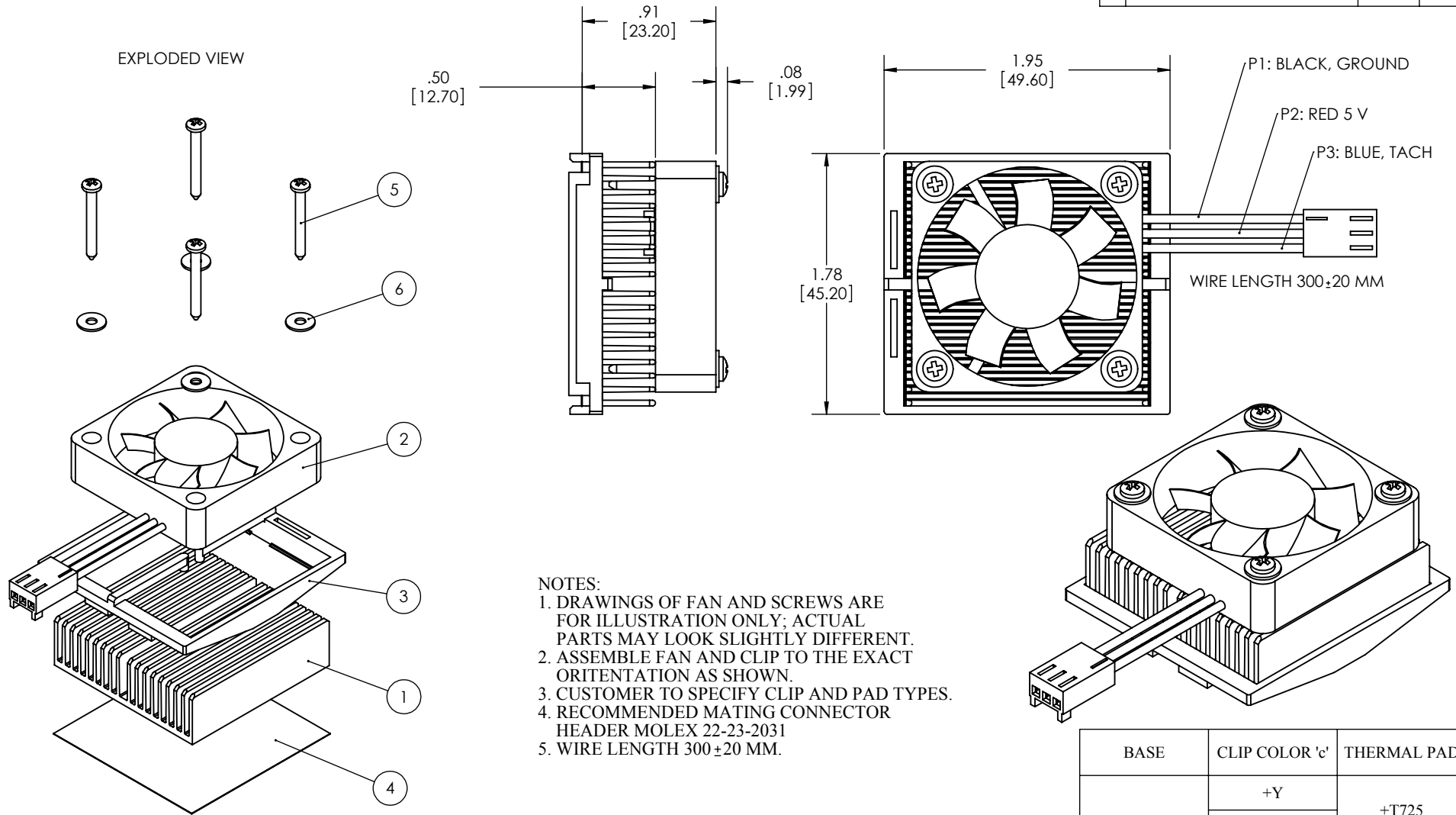

- NOTES:
1. DRAWINGS OF FAN AND SCREWS ARE FOR ILLUSTRATION ONLY; ACTUAL PARTS MAY LOOK SLIGHTLY DIFFERENT.
 2. ASSEMBLE FAN AND CLIP TO THE EXACT ORIENTATION AS SHOWN.
 3. CUSTOMER TO SPECIFY CLIP AND PAD TYPES.
 4. RECOMMENDED MATING CONNECTOR HEADER MOLEX 22-23-2031
 5. WIRE LENGTH 300±20 MM.

BASE	CLIP COLOR 'c'	THERMAL PAD
FJ42.5	+Y	+T725
	+BU	
	+O	+OTHER

EXAMPLE PART NUMBER: FJ42.5+Y+T725

ITEM NO.	PART NUMBER	DESCRIPTION	QTY.
1	INL42.5001-13/1.7	42.5MM HEAT SINK	1
2	HS8074	5V 40X40X10MM DC FAN WITH CONNECTOR	1
3	BCP5045-08(42.5)c	42.5 MM EZ SNAP CLIP (SEE TABLE ON THE RIGHT FOR CLIP CODE c)	1
4	OPTIONAL	THERMAL PAD 1.67X1.67" OR FULL COVERAGE	1
5	2N75PPAZB	#2 X 3/4 PHIL PAN SMS BLK (RoHS)	4
6	960-2B	#2 FLAT WASHER, SEE NOTE 2	4

MATERIAL	APPROVALS	DATE
FINISH	DRAWN	04/28/09
UNLESS OTHERWISE SPECIFIED DIMENSIONS ARE IN INCHES TOLERANCES ARE: 2 PLACE DECIMALS: ± .010 3 PLACE DECIMALS: ± .005 ANGLES: ± 1°	CHECKED	04/28/09
THIRD ANGLE PROJECTION	FWANG	
	MFG ENG	
	QUAL ENG	
	SHEET 1 OF 1	



RADIAN HEATSINKS
DIV. OF INTRICAST CO. INC.
2160 WALSH AVE
SANTA CLARA, CA 95050

42.5 MM 5V DC FANSINK
WITH LOW PROFILE EZ-SNAP CLIP

SIZE DWG. NO. FJ42.5

REV. C