

THE INFORMATION CONTAINED IN THIS DRAWING IS THE SOLE PROPERTY OF RADIAN HEATSINKS AND ANY REPRODUCTION IN PART OR IN WHOLE IS STRICTLY PROHIBITED WITHOUT THE WRITTEN PERMISSION OF RADIAN HEATSINKS.

REV	DESCRIPTION OF REVISIONS	APPROVED	DATE
A	INITIAL RELEASE	FWANG	03/09/07
B	PER ECN#706251	FWANG	06/25/07
C	PER ECN#707251	FWANG	07/25/07
D	PER ECN#005051	FWANG	05/06/10

EXPLODED VIEW

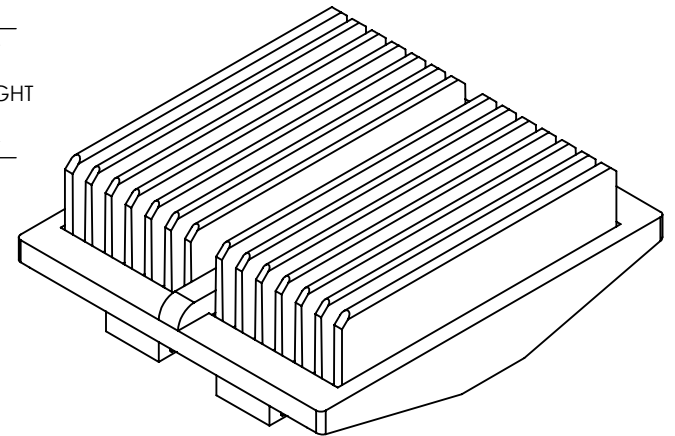
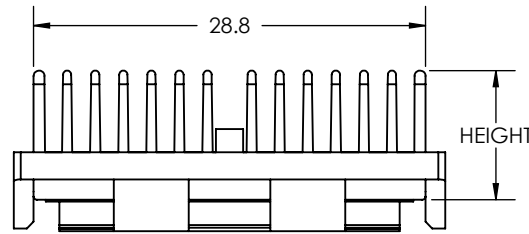
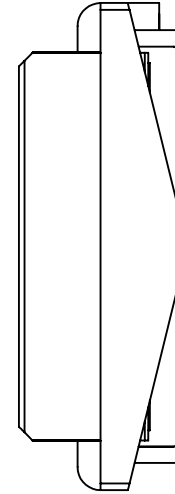
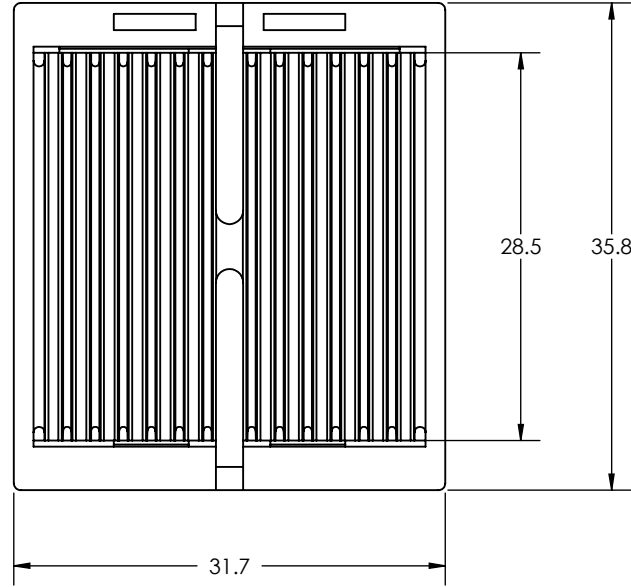
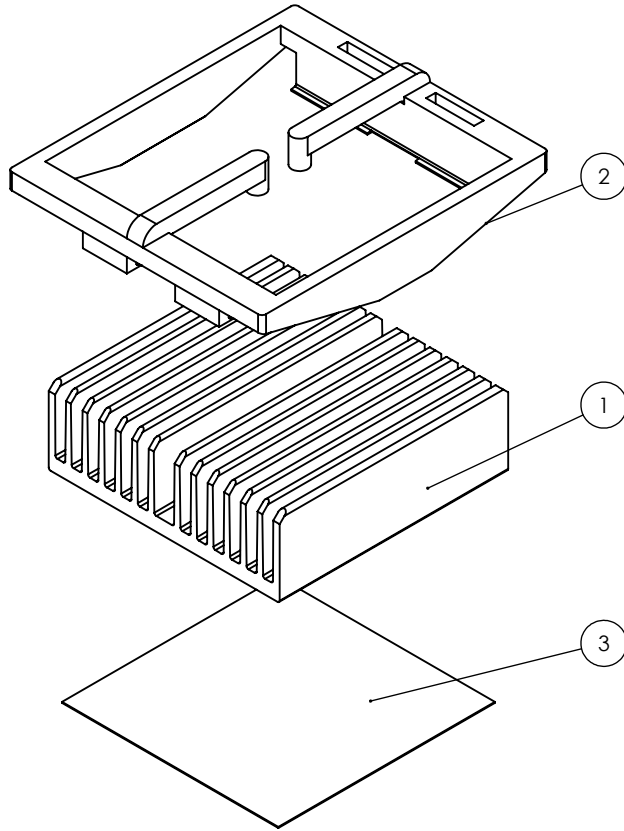

ITEM NO.	PART NUMBER	DESCRIPTION	QTY.
1	INL29001-hh/1.7	29MM PLATE FIN HEAT SINK	1
2	BCP3632-08(29)c	OPTIONAL 29MM LOW PROFILE CLIP	1
3	OPTIONAL	THERMAL PAD 27 X 27 MM OR FULL COVERAGE OF HEAT SINK BASE	1

NOTE: SEE THE TABLE BELOW FOR COMPLETE PART NUMBER WITH OPTIONS.

COMPLETE PART NUMBER WITH OPTIONS				
ROOT	HEIGHT	BASE	CLIP	PAD
INL29001-	6 (6.3 MM)	/1.7 (1.7 MM)	Y (YELLOW)	+T725
	10 (9.5 MM)		BU (BLUE)	
	13 (12.7 MM)		O (ORANGE)	
EXAMPLE PART NUMBER: INL29001-10/1.7BU+T725				

MATERIAL	APPROVALS	DATE	 RADIAN HEATSINKS DIV. OF INTRICAST CO. INC. 2160 WALSH AVE SANTA CLARA, CA 95050
FINISH	DRAWN AREDDY	03/09/07	
UNLESS OTHERWISE SPECIFIED DIMENSIONS ARE IN MM TOLERANCES ARE: 0-1 PLACE DECIMALS: ± .25 2 PLACE DECIMALS: ± .10 ANGLES: ± 1°	CHECKED FWANG	03/09/07	
	MFG ENG	QUAL ENG.	
THIRD ANGLE PROJECTION	SHEET 1 OF 1		SIZE DWG. NO. A INL29001
			REV. D