

THE INFORMATION CONTAINED IN THIS DRAWING IS THE SOLE PROPERTY OF RADIAN HEATSINKS AND ANY REPRODUCTION IN PART OR IN WHOLE IS STRICTLY PROHIBITED WITHOUT THE WRITTEN PERMISSION OF RADIAN HEATSINKS.

REV	DESCRIPTION OF REVISIONS	APPROVED	DATE
A	INITIAL RELEASE	FWANG	08/28/07

EXPLODED VIEW

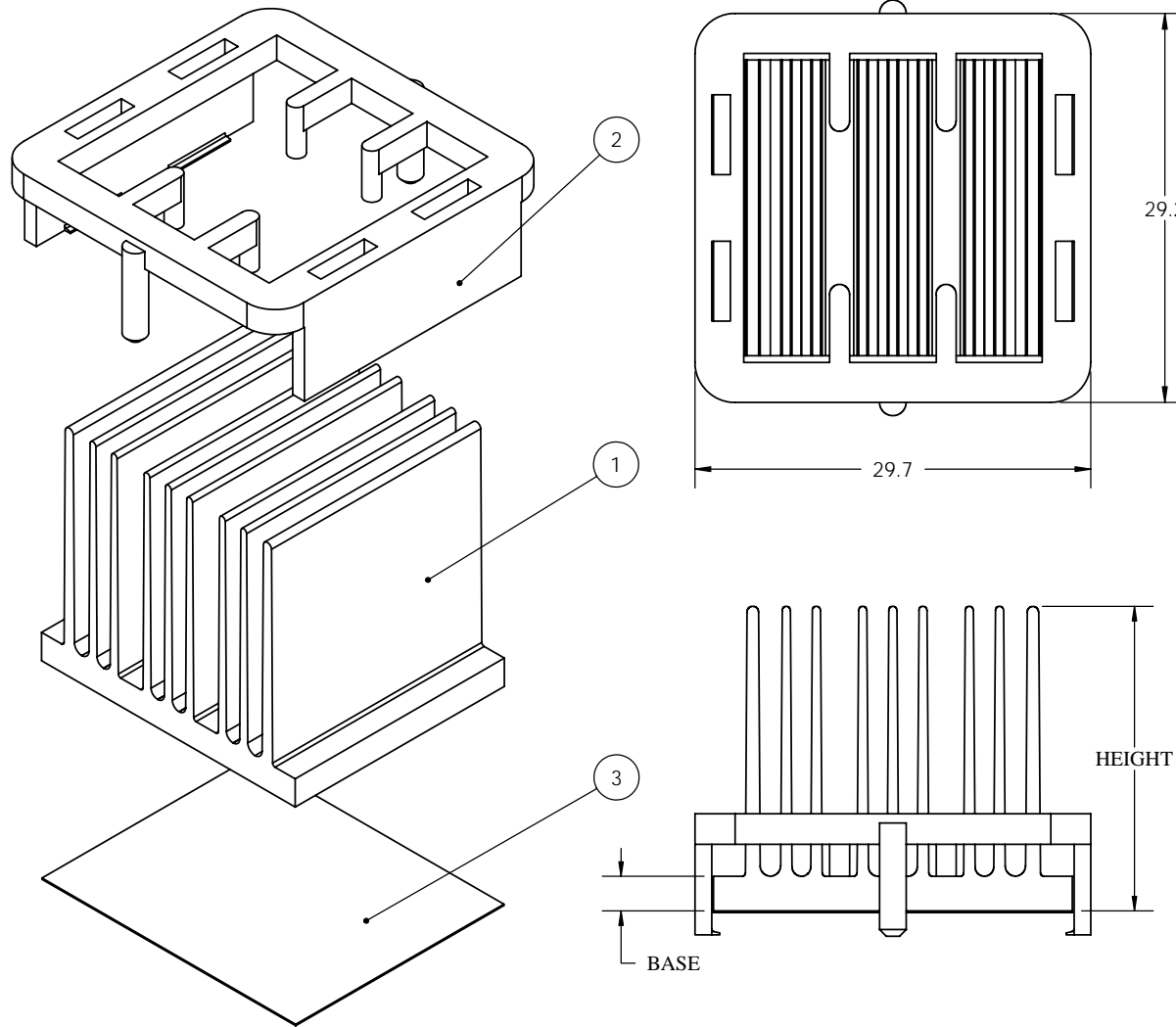

NOTES:

1. CUSTOMER TO SPECIFY HEIGHT, BASE, TYPE OF CLIP AND PAD.
2. RECOMMENDED KEEP-OUT AREA: 32X32 MM
3. CLIP SELECTION IS BASED ON THE CHIP HEIGHT(EXCLUDING THE SOLDER BALL HEIGHT OF 0.25MM)

CHIP HEIGHT	CLIP
3.3±0.3MM	BCP30-09(27)Y
2.6±0.3MM	K32
1.7±0.3MM	BCP30-09(27)BU
0.9±0.3MM	BCP30-09(27)O

COMPLETE PART NUMBER WITH OPTIONS				
ROOT	HEIGHT (MM)	BASE (MM)	CLIP	PAD
INH27001-	15 (14.6)	/2.6	K32	+T710
	18 (17.6)			
	21 (20.6)	/OTHER	Y	+OTHER
	23 (22.86)		BU	
OTHER (MM)		O		

EXAMPLE PART NUMBER: INH27001-23/2.6BU+T710

ITEM NO	PART NO	DESCRIPTION	QTY
1	INH27001-hh	27MM PLATE FIN HEAT SINK (SEE TABLE ON THE RIGHT FOR HEIGHT CODE hh)	1
2	OPTIONAL	27MM EZ-SNAP CLIP (SEE TABLE ON THE RIGHT UNDER CLIP)	1
3	OPTIONAL	THERMAL INTERFACE PAD 1.06 X 0.87"	1

MATERIAL	APPROVALS	DATE
FINISH	DRAWN AREDDY	08/28/07
UNLESS OTHERWISE SPECIFIED DIMENSIONS ARE IN MM TOLERANCES ARE: 1 PLACE DECIMALS: ± .25 2 PLACE DECIMALS: ± .10 ANGLES: ± 1°	CHECKED FWANG	08/28/07
	MFG ENG	
	QUAL ENG	
	THIRD ANGLE PROJECTION	SHEET 1 OF 1



RADIAN HEATSINKS
DIV. OF INTRICAST CO. INC.
2160 WALSH AVE
SANTA CLARA, CA 95050

27MM HEAT SINK ASSEMBLY

SIZE	DWG. NO.	REV.
A	INH27001	A