

THE INFORMATION CONTAINED IN THIS DRAWING IS THE SOLE PROPERTY OF RADIAN HEATSINKS AND ANY REPRODUCTION IN PART OR IN WHOLE IS STRICTLY PROHIBITED WITHOUT THE WRITTEN PERMISSION OF RADIAN HEATSINKS.

REV	DESCRIPTION OF REVISIONS	APPROVED	DATE
A	INITIAL RELEASE	FWANG	08/28/07

EXPLODED VIEW

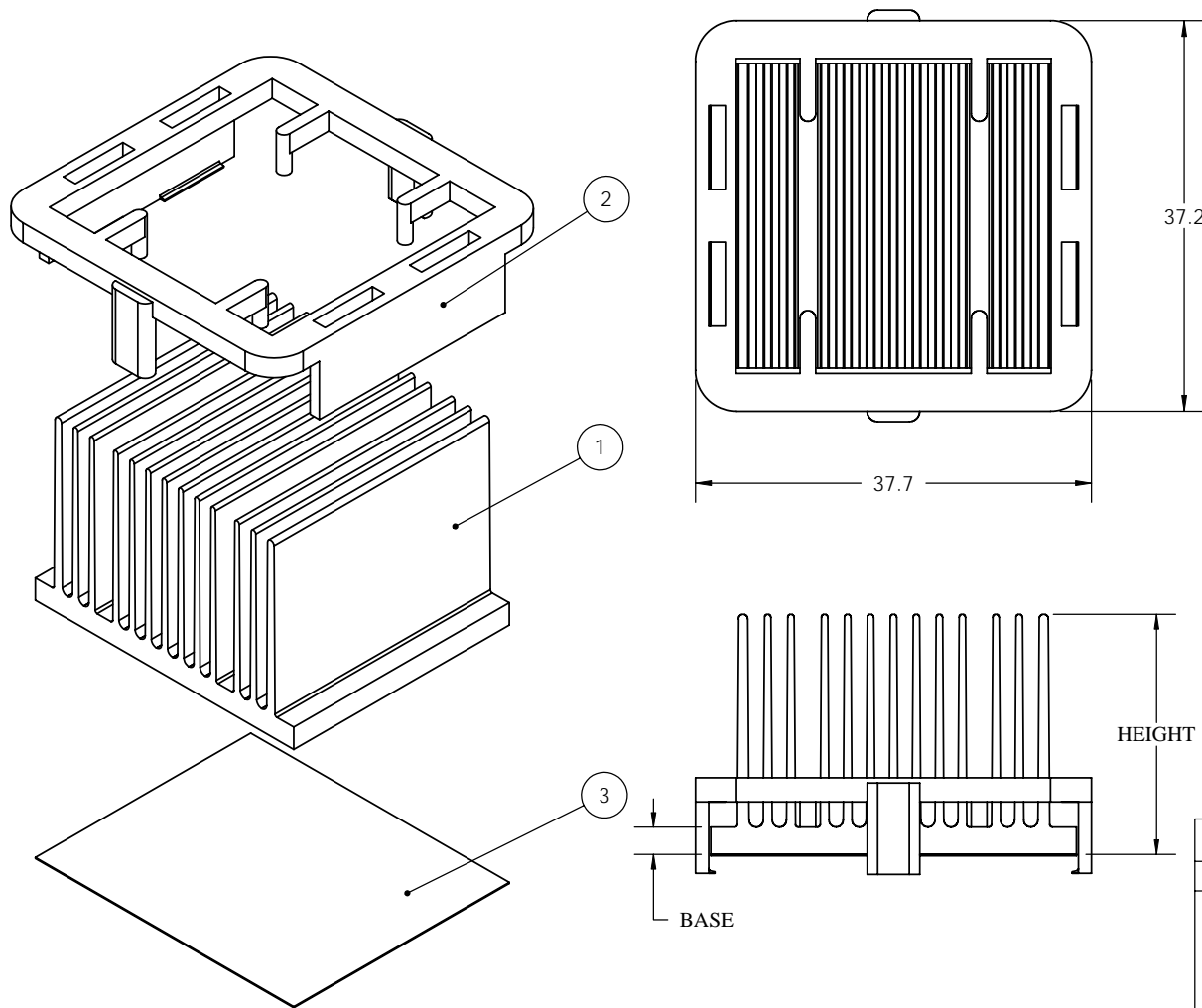

NOTES:

1. CUSTOMER TO SPECIFY HEIGHT, BASE, TYPE OF CLIP AND PAD.
2. RECOMMENDED KEEP-OUT AREA: 40X40 MM
3. CLIP SELECTION IS BASED ON THE CHIP HEIGHT (EXCLUDING THE SOLDER BALL HEIGHT OF 0.25MM)

CHIP HEIGHT	CLIP
3.3±0.3MM	BCP37-09(35)Y
2.6±0.3MM	K29
1.7±0.3MM	BCP37-09(35)BU
0.9±0.3MM	BCP37-09(35)O

COMPLETE PART NUMBER WITH OPTIONS				
ROOT	HEIGHT (MM)	BASE (MM)	CLIP	PAD
INH35001-	12 (11.6)	/2.6	K29	+T710
	15 (14.6)			
	18 (17.6)			
	21 (20.6)	/OTHER	Y	
	23 (22.86)		BU	
OTHER (MM)	O	+OTHER		

EXAMPLE PART NUMBER: INH35001-23/2.6BU+T710

ITEM NO	PART NUMBER	DESCRIPTION	QTY
1	INH35001-hh	35MM PLATE FIN HEAT SINK (SEE TABLE ON THE RIGHT FOR HEIGHT CODE hh)	1
2	OPTIONAL	35MM EZ-SNAP CLIP (SEE TABLE ON THE RIGHT UNDER CLIP)	1
3	OPTIONAL	THERMAL INTERFACE PAD 1.38 X 1.14"	1

MATERIAL	APPROVALS	DATE
FINISH	DRAWN AREDDY	08/28/07
UNLESS OTHERWISE SPECIFIED DIMENSIONS ARE IN MM TOLERANCES ARE: 1 PLACE DECIMALS: ± .25 2 PLACE DECIMALS: ± .10 ANGLES: ± 1°	CHECKED	FWANG
	MFG ENG	08/28/07
	QUAL ENG	
THIRD ANGLE PROJECTION	SHEET 1 OF 1	



RADIAN HEATSINKS
DIV. OF INTRICAST CO. INC.
2160 WALSH AVE
SANTA CLARA, CA 95050

35MM HEAT SINK ASSEMBLY

SIZE	DWG. NO.	REV.
A	INH35001	A