

THE INFORMATION CONTAINED IN THIS DRAWING IS THE SOLE PROPERTY OF RADIAN HEATSINKS AND ANY REPRODUCTION IN PART OR IN WHOLE IS STRICTLY PROHIBITED WITHOUT THE WRITTEN PERMISSION OF RADIAN HEATSINKS.

REV	DESCRIPTION OF REVISIONS	APPROVED	DATE
A	INITIAL RELEASE	SM	7/11/18

EXPLODED VIEW

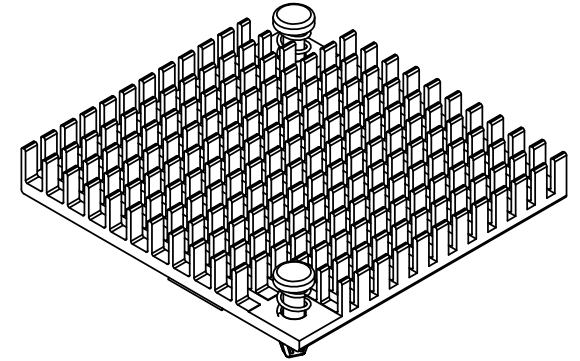
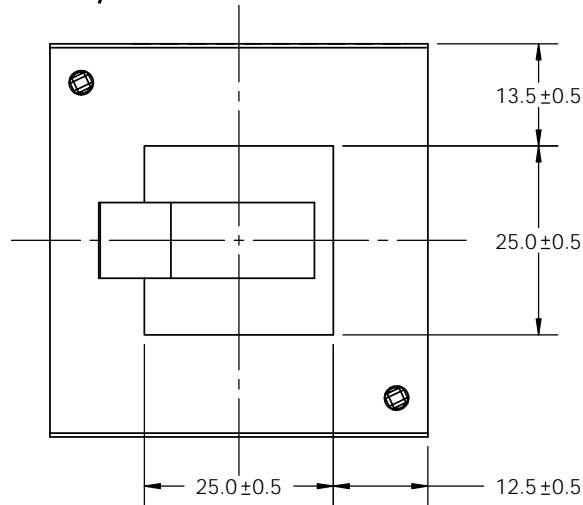
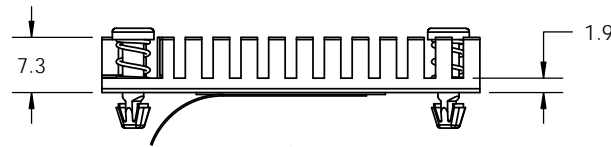
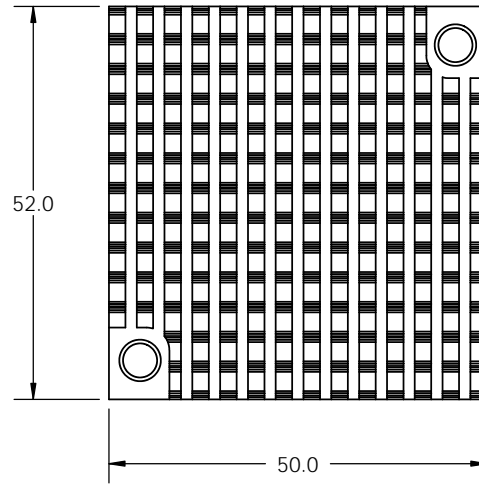
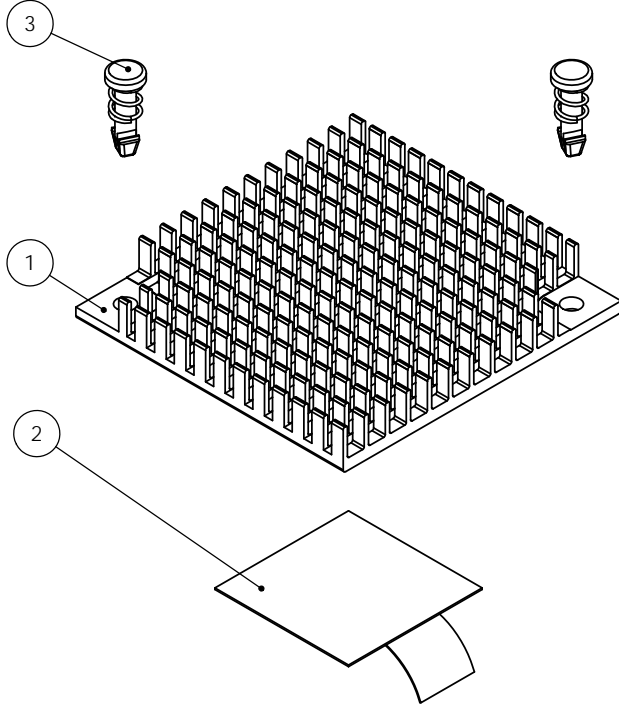

NOTES:
1. PART TO BE RoHS COMPLIANT.

ITEM NO.	PART NUMBER	DESCRIPTION	QTY.
1	EMU093	CROSS CUT EXTRUSION HEAT SINK	1
2	P1309	CHOMERICS T725 PAD 25X25 MM WITH PULL TAB	1
3	HS8138	PUSHMAGIC PUSH PIN	2

MATERIAL	APPROVALS	DATE
FINISH	DRAWN	3/9/2012
UNLESS OTHERWISE SPECIFIED DIMENSIONS ARE IN MM TOLERANCES ARE: 1 PLACE DECIMALS: ± 0.25 2 PLACE DECIMALS: ± 0.10 ANGLES: ± 1°	CHECKED	3/9/2012
	MFG ENG	
	QUAL ENG	
THIRD ANGLE PROJECTION	SHEET 1 OF 1	

 RADIAN HEATSINKS RADIAN THERMAL PRODUCTS, INC. 2160 WALSH AVE SANTA CLARA, CA 95050	HEAT SINK ASSEMBLY	
	SIZE	DWG. NO.
	A	PCI1094
REV.	A	

THE INFORMATION CONTAINED IN THIS DRAWING IS THE SOLE PROPERTY OF RADIAN HEATSINKS AND ANY REPRODUCTION IN PART OR IN WHOLE IS STRICTLY PROHIBITED WITHOUT THE WRITTEN PERMISSION OF RADIAN HEATSINKS.

REV	DESCRIPTION OF REVISIONS	APPROVED	DATE
A	INITIAL RELEASE	BQ	08/23/12
B	ECN307221: UPDATE EMULEX PN	BO	7/22/13

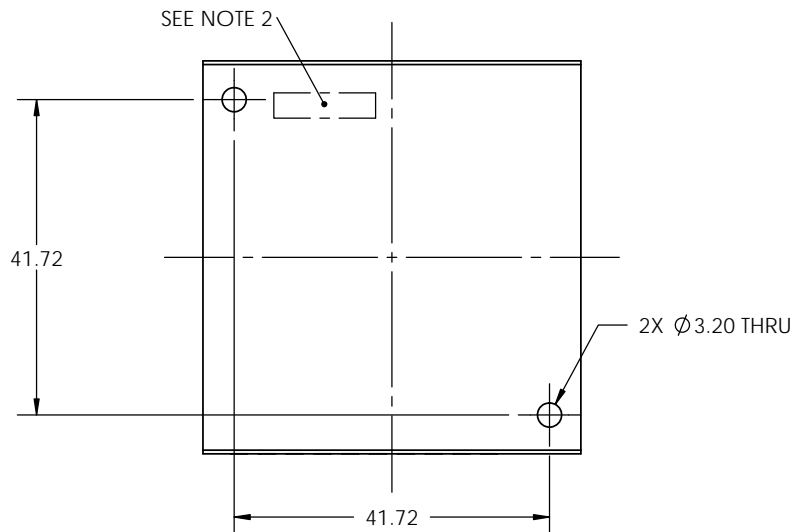
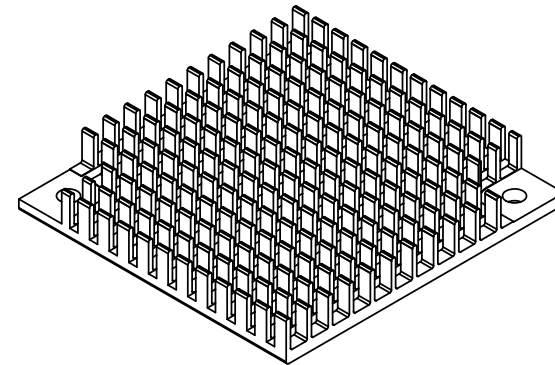
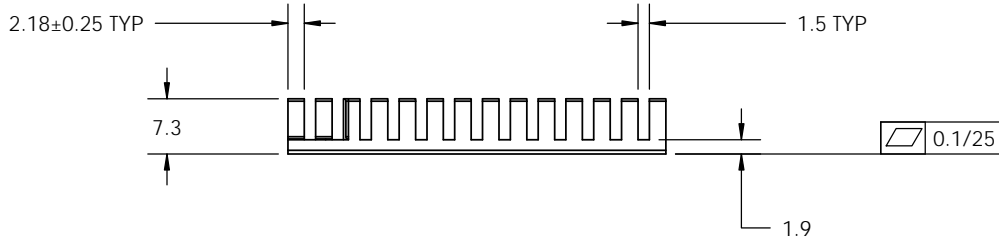
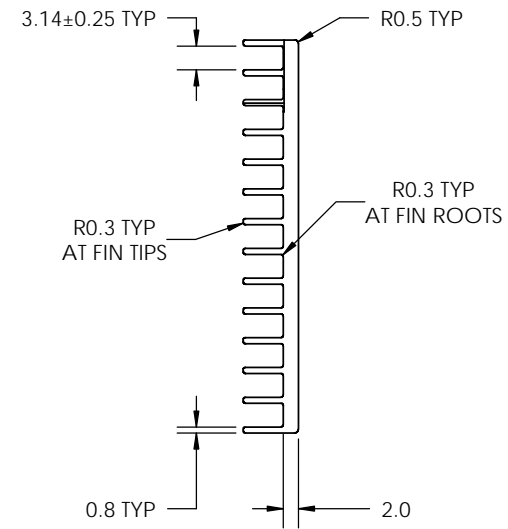
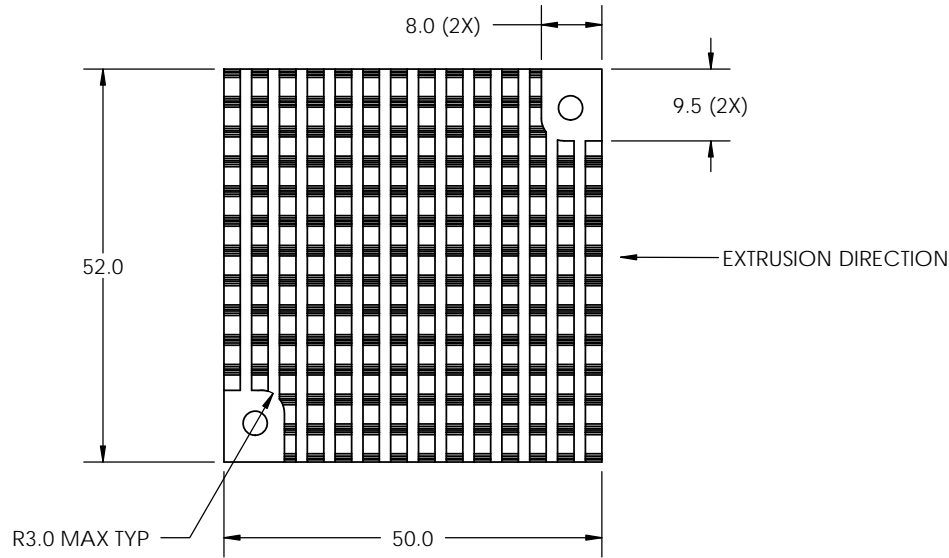

- NOTES:
1. ANODIZE PER MIL-A-8625 TYII CL2 BLACK.
 2. MARK PART NUMBER "P008126-01A" APPROXIMATELY HERE, TEXT HEIGHT 2-3 MM.
 3. MAX DRAFT ANGLE 0.5° IS ALLOWED.
 4. PART TO BE FREE OF BURRS.
 5. PART TO BE RoHS COMPLIANT.

MATERIAL	A6061/A6063	APPROVALS	DATE	 RADIAN HEATSINKS RADIAN THERMAL PRODUCTS, INC. 2160 WALSH AVE SANTA CLARA, CA 95050	
FINISH	SEE NOTE 1	DRAWN	3/9/2012		
UNLESS OTHERWISE SPECIFIED DIMENSIONS ARE IN MM TOLERANCES ARE: 1 PLACE DECIMALS: ± 0.25 2 PLACE DECIMALS: ± 0.10 ANGLES: ± 1°	CHECKED	DDINH	3/9/2012		
	MFG ENG	QUAL ENG			
THIRD ANGLE PROJECTION	SHEET 1 OF 1		SIZE	DWG. NO.	REV.
			A	EMU093	B