

THE INFORMATION CONTAINED IN THIS DRAWING IS THE SOLE PROPERTY OF RADIAN HEAT SINKS AND ANY REPRODUCTION IN PART OR IN WHOLE IS STRICTLY PROHIBITED WITHOUT THE WRITTEN PERMISSION OF RADIAN HEATSINKS.

REVISIONS			
REV.	DESCRIPTION	DATE	APPROVED
A	NEW RELEASE	9/22/05	FWANG
B	ECN#705211: UPDATED PAD SIZE AND CLIP	7/21/07	FWANG
C	PER ECN#005051	05/05/10	FWANG

**EXPLODED VIEW**

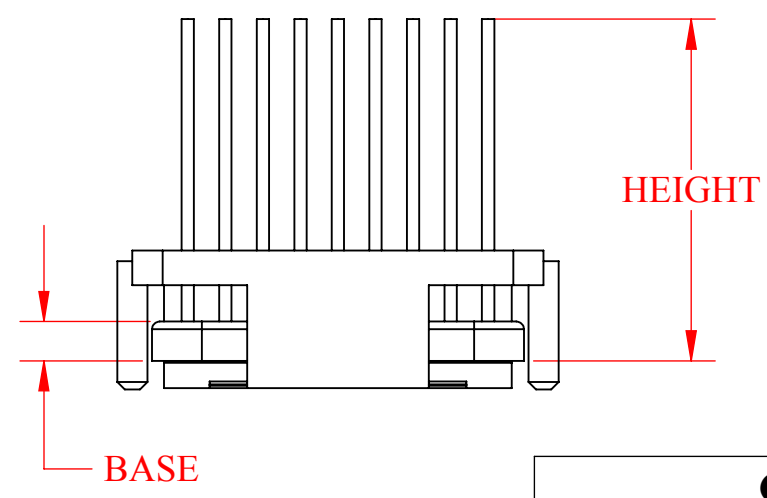
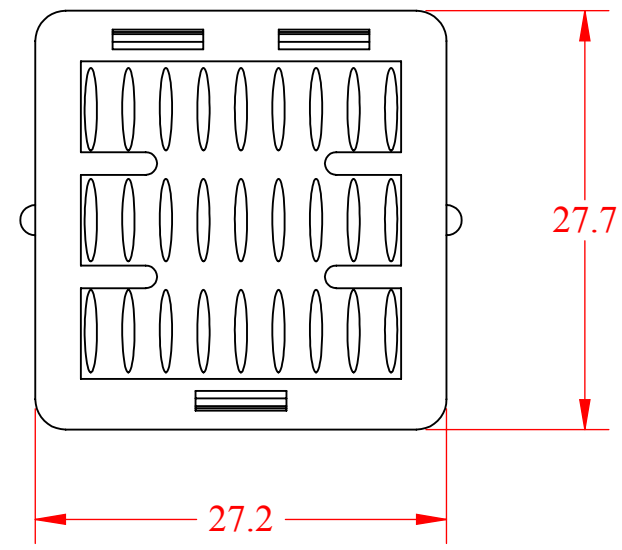
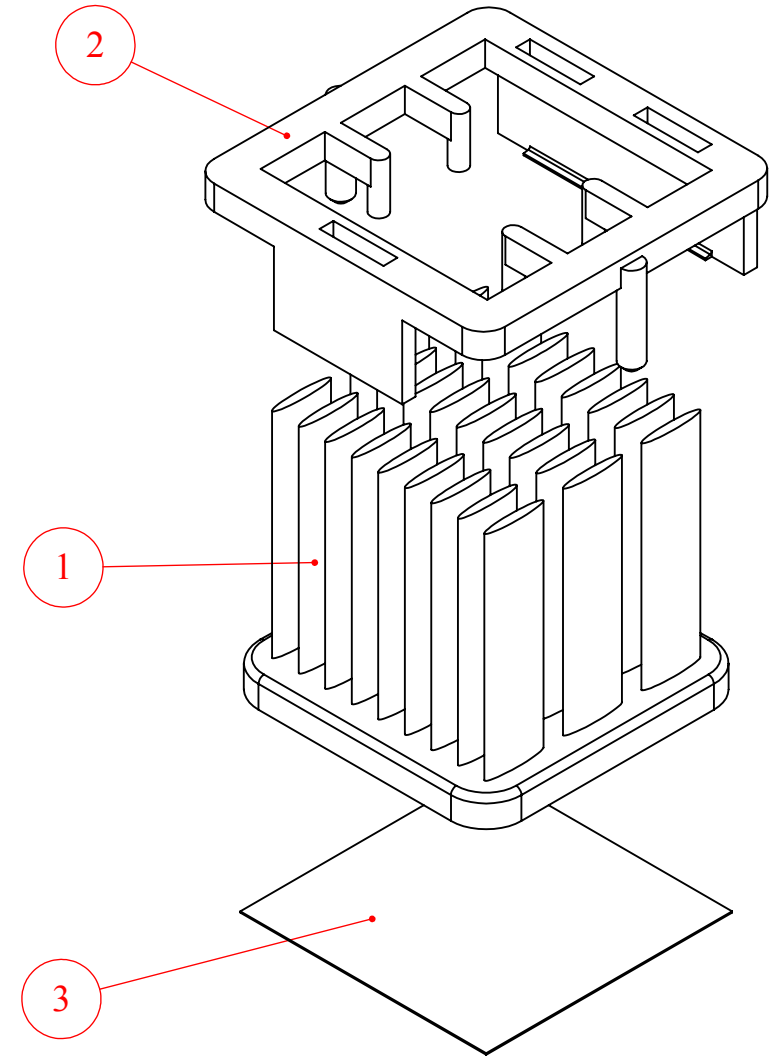

**NOTES:**

1. SEE TABLE BELOW FOR COMPLETE PART NUMBER WITH OPTIONS.
2. RECOMMENDED KEEP-OUT AREA: 30X30 MM.
3. COLOR OF CLIP TO BE SELECTED BASED ON CHIP HEIGHT AS ILLUSTRATED BELOW.
4. CLIP FITS MIN. 0.25 MM SOLDER BALL HEIGHT.

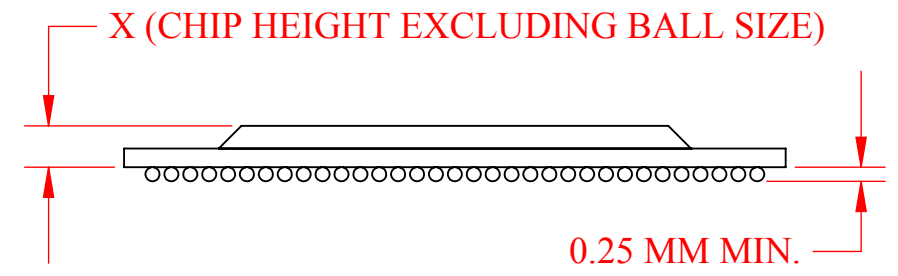

X	CLIP COLOR
3.3±0.3 MM	YELLOW
1.7±0.3 MM	BLUE
0.9±0.3 MM	ORANGE

COMPLETE PART NUMBER WITH OPTIONS				
ROOT	HEIGHT (hh)	BASE	CLIP (c)	PAD
INM25001-	15W (14.6 MM)	/2.6 (2.6 MM)	Y (YELLOW)	+T710
	18W (17.6 MM)			
	21W (20.6 MM)		O (ORANGE)	+OTHER
	23W (22.6 MM)			
	28W (27.6 MM)			
33W (32.6 MM)				
EXAMPLE PART NUMBER: INM25001-23W/2.6BU+T710				

ITEM NO.	PART NUMBER	DESCRIPTION	QTY.
1	INM25001-hhW/2.6	ELLIPTICAL HEAT SINK (SEE TABLE ON THE RIGHT FOR HEIGHT CODE hh)	1
2	BCP28-09(25)c	25 MM EZ-SNAP CLIP (SEE TABLE ON THE RIGHT FOR CLIP CODE c)	1
3	OPTIONAL	THERMAL PAD 23X23 MM OR FULL COVERAGE OF HEAT SINK BASE	1

UNLESS OTHERWISE SPECIFIED DIMENSIONS ARE IN MM TOLERANCES ARE:		CAD GENERATED DRAWING, DO NOT MANUALLY UPDATE		 <b>RADIAN HEATSINKS</b> DIV. OF INTRICAST CO. INC. 2160 WALSH AVE SANTA CLARA, CA - 95050
DECIMALS	ANGLES	APPROVALS	DATE	
X. ±.25	± 1°	DRAWN	9/22/05	<b>25 MM ELLIPTICAL HEAT SINK</b>  SIZE B DWG. NO. <b>INM25001</b> REV. <b>C</b>
X.X ±.25		CHECKED	9/23/05	
X.XX ±.10		RESP ENG	9/22/05	
		MFG ENG		
MATERIAL		QUAL ENG		
FINISH		DO NOT SCALE DRAWING		
NEXT ASSY USED ON		APPLICATION		