

THE INFORMATION CONTAINED IN THIS DRAWING IS THE SOLE PROPERTY OF RADIAN HEAT SINKS AND ANY REPRODUCTION IN PART OR IN WHOLE IS STRICTLY PROHIBITED WITHOUT THE WRITTEN PERMISSION OF RADIAN HEATSINKS.

REVISIONS			
REV.	DESCRIPTION	DATE	APPROVED
A	NEW RELEASE	9/22/05	FWANG
B	ECN#705211: UPDATED PAD SIZE AND CLIP	7/21/07	FWANG
C	PER ECN#005051	05/05/10	FWANG

**EXPLODED VIEW**

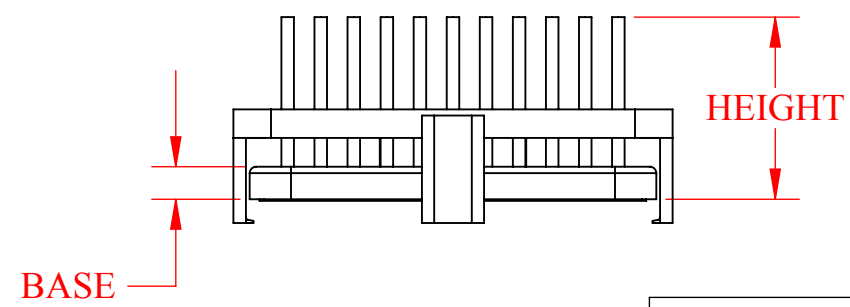
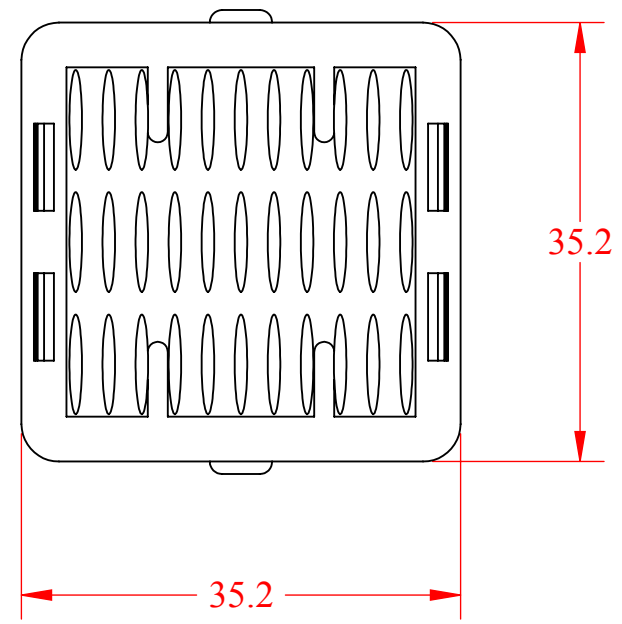
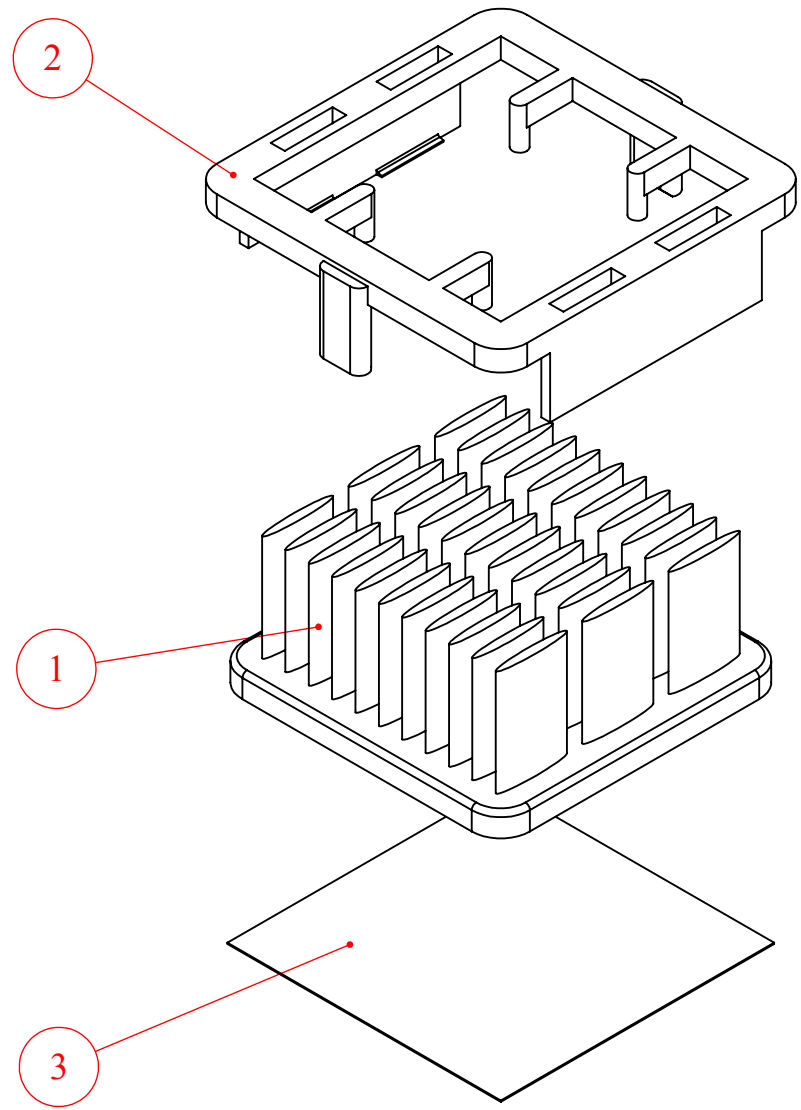

**NOTES:**

- SEE TABLE BELOW FOR COMPLETE PART NUMBER WITH OPTIONS.
- RECOMMENDED KEEP-OUT AREA: 38X38 MM.
- COLOR OF CLIP TO BE SELECTED BASED ON CHIP HEIGHT AS ILLUSTRATED BELOW.
- CLIP FITS MIN. 0.25 MM SOLDER BALL HEIGHT.

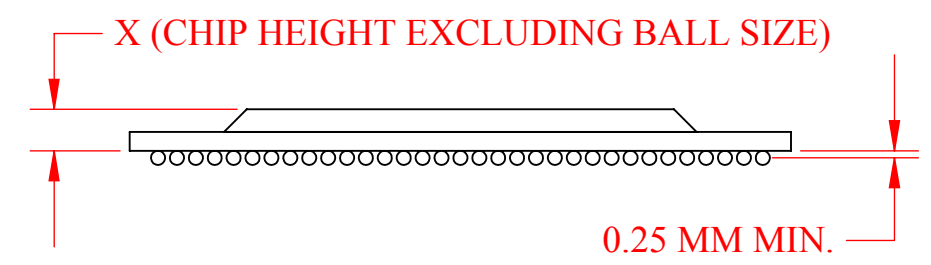

X	CLIP COLOR
3.3±0.3 MM	YELLOW
1.7±0.3 MM	BLUE
0.9±0.3 MM	ORANGE

ITEM NO.	PART NUMBER	DESCRIPTION	QTY.
1	INM33001-hhW/2.6	ELLIPTICAL HEAT SINK (SEE TABLE ON THE RIGHT FOR HEIGHT CODE hh)	1
2	BCP35-09(33)c	33 MM EZ-SNAP CLIP (SEE TABLE ON THE RIGHT FOR CLIP CODE c)	1
3	OPTIONAL	THERMAL PAD (31X31 MM OR FULL COVERAGE OF HEAT SINK BASE)	1

COMPLETE PART NUMBER WITH OPTIONS				
ROOT	HEIGHT (hh)	BASE	CLIP (c)	PAD
INM33001-	15W (14.6 MM)	/2.6 (2.6 MM)	Y (YELLOW)	+T710
	18W (17.6 MM)		BU (BLUE)	
	21W (20.6 MM)		O (ORANGE)	+OTHER
	23W (22.6 MM)		K33	
	28W (27.6 MM)			
33W (32.6 MM)				

EXAMPLE PART NUMBER: INM33001-23W/2.6BU+T710

SHEET 1 OF 1		UNLESS OTHERWISE SPECIFIED DIMENSIONS ARE IN MM TOLERANCES ARE: DECIMALS ANGLES X. ±.25 ±1° X.X ±.25 X.XX ±.10		CAD GENERATED DRAWING, DO NOT MANUALLY UPDATE		 <b>RADIAN HEATSINKS</b> DIV. OF INTRICAST CO. INC. 2160 WALSH AVE SANTA CLARA, CA - 95050  <b>33 MM ELLIPTICAL HEAT SINK</b>
APPLICATION		DO NOT SCALE DRAWING		APPROVALS DATE	REV. C	
NEXT ASSY USED ON		FINISH		DRAWN FWANG 9/22/05		
		MATERIAL		CHECKED TSIN 9/23/05		
				RESP ENG FWANG 9/22/05		
				MFG ENG		
				QUAL ENG		
				SIZE B DWG. NO. INM33001		