

THE INFORMATION CONTAINED IN THIS DRAWING IS THE SOLE PROPERTY OF RADIAN HEAT SINKS AND ANY REPRODUCTION IN PART OR IN WHOLE IS STRICTLY PROHIBITED WITHOUT THE WRITTEN PERMISSION OF RADIAN HEATSINKS.

REVISIONS			
REV.	DESCRIPTION	DATE	APPROVED
A	NEW RELEASE	9/22/05	FWANG
B	ECN#705211: UPDATED PAD SIZE AND CLIP	7/21/07	FWANG
C	PER ECN#005051	05/05/10	FWANG

EXPLODED VIEW

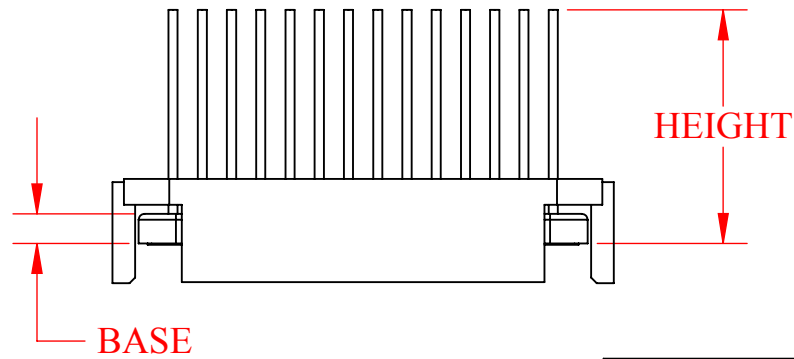
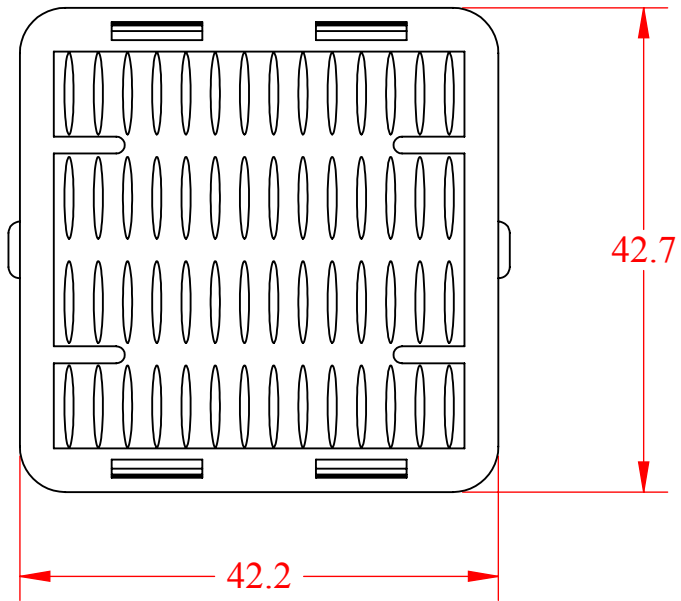
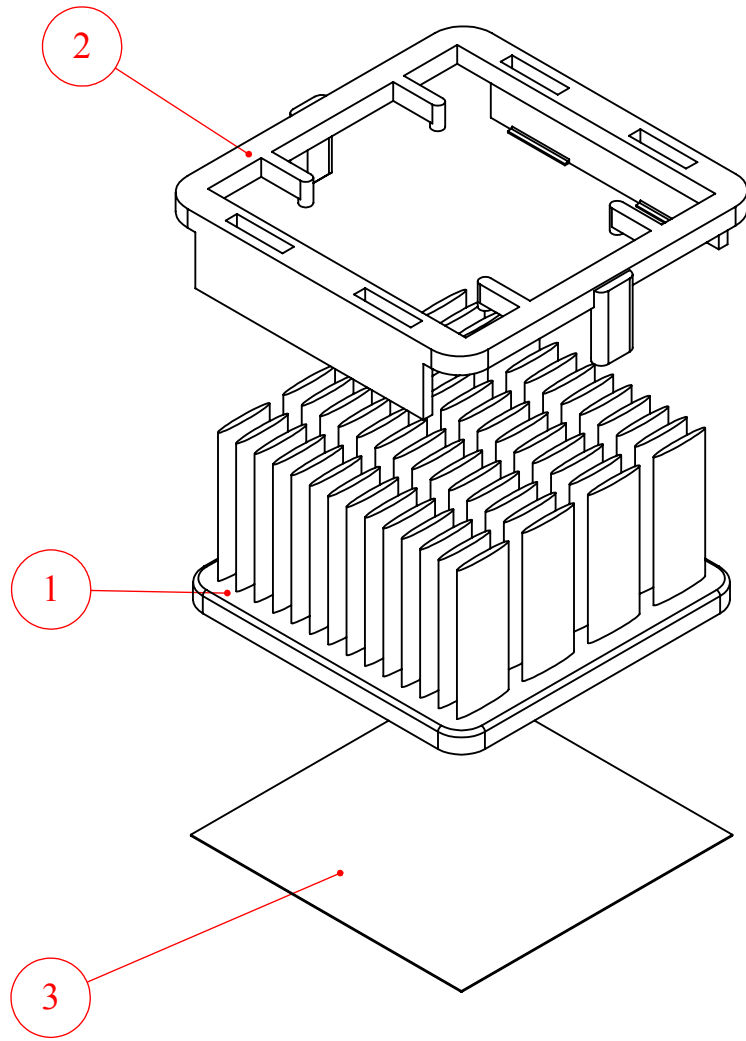

NOTES:

- SEE TABLE BELOW FOR COMPLETE PART NUMBER WITH OPTIONS.
- RECOMMENDED KEEP-OUT AREA: 45X45 MM.
- COLOR OF CLIP TO BE SELECTED BASED ON CHIP HEIGHT AS ILLUSTRATED BELOW.

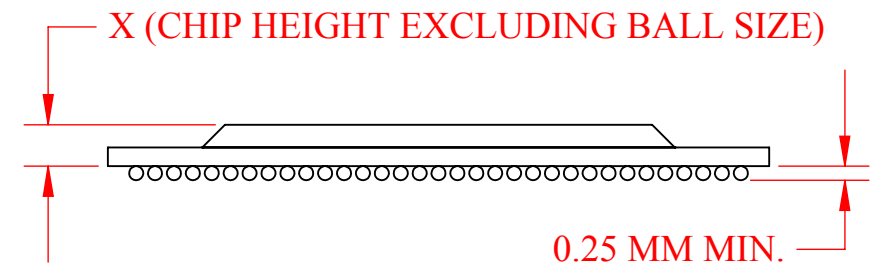

X	CLIP COLOR
3.3±0.3 MM	YELLOW
1.7±0.3 MM	BLUE
0.9±0.3 MM	ORANGE

COMPLETE PART NUMBER WITH OPTIONS

ROOT	HEIGHT (hh)	BASE	CLIP (c)	PAD	
INM40001-	15W (14.6 MM)	/2.6 (2.6 MM)	Y (YELLOW)	+T710	
	18W (17.6 MM)		K30		
	21W (20.6 MM)			BU (BLUE)	+OTHER
	23W (22.6 MM)			O (ORANGE)	
	28W (27.6 MM)				
33W (32.6 MM)					

EXAMPLE PART NUMBER: INM40001-23W/2.6BU+T710

ITEM NO.	PART NUMBER	DESCRIPTION	QTY.
1	INM40001-hhW/2.6	ELLIPTICAL HEAT SINK (SEE TABLE ON THE RIGHT FOR HEIGHT CODE hh)	1
2	BCP43-09(40)c	40 MM EZ-SNAP CLIP (SEE TABLE ON THE RIGHT FOR CLIP CODE c)	1
3	OPTIONAL	THERMAL PAD (38X38 MM OR FULL COVERAGE OF HEAT SINK BASE)	1

UNLESS OTHERWISE SPECIFIED DIMENSIONS ARE IN MM TOLERANCES ARE: DECIMALS ANGLES X. ±.25 ±1° X.X ±.25 X.XX ±.10		CAD GENERATED DRAWING, DO NOT MANUALLY UPDATE		 RADIAN HEATSINKS DIV. OF INTRICAST CO. INC. 2160 WALSH AVE SANTA CLARA, CA - 95050 40 MM ELLIPTICAL HEAT SINK
APPROVALS		DATE		
DRAWN FWANG		9/22/05		
CHECKED TSIN		9/23/05		
RESP ENG FWANG		9/22/05		
MATERIAL		FINISH		SIZE B
NEXT ASSY USED ON		DO NOT SCALE DRAWING		DWG. NO. INM40001
APPLICATION				REV. C