

REVISIONS			
REV.	DESCRIPTION	DATE	APPROVED
A	NEW RELEASE	9/22/05	FWANG
B	ECN#705211: UPDATED PAD DIZE AND CLIP	7/21/07	FWANG
C	PER ECN#005051	05/05/10	FWANG

HEATSINKS.

EXPLODED VIEW

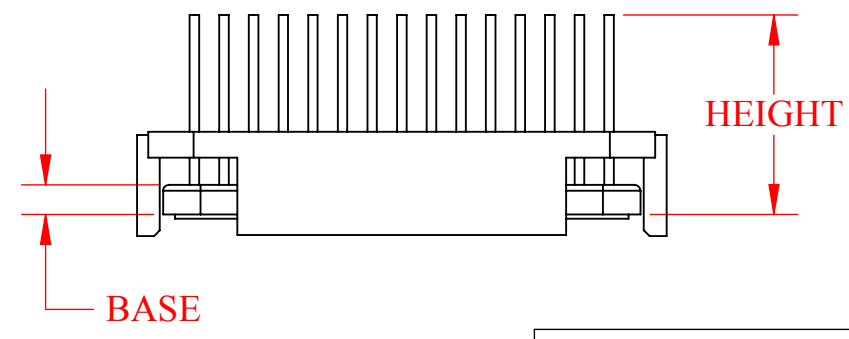
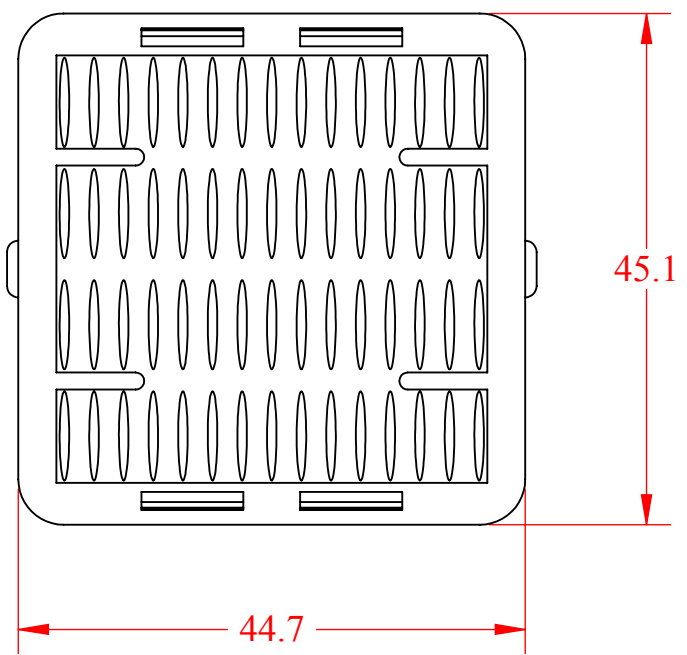
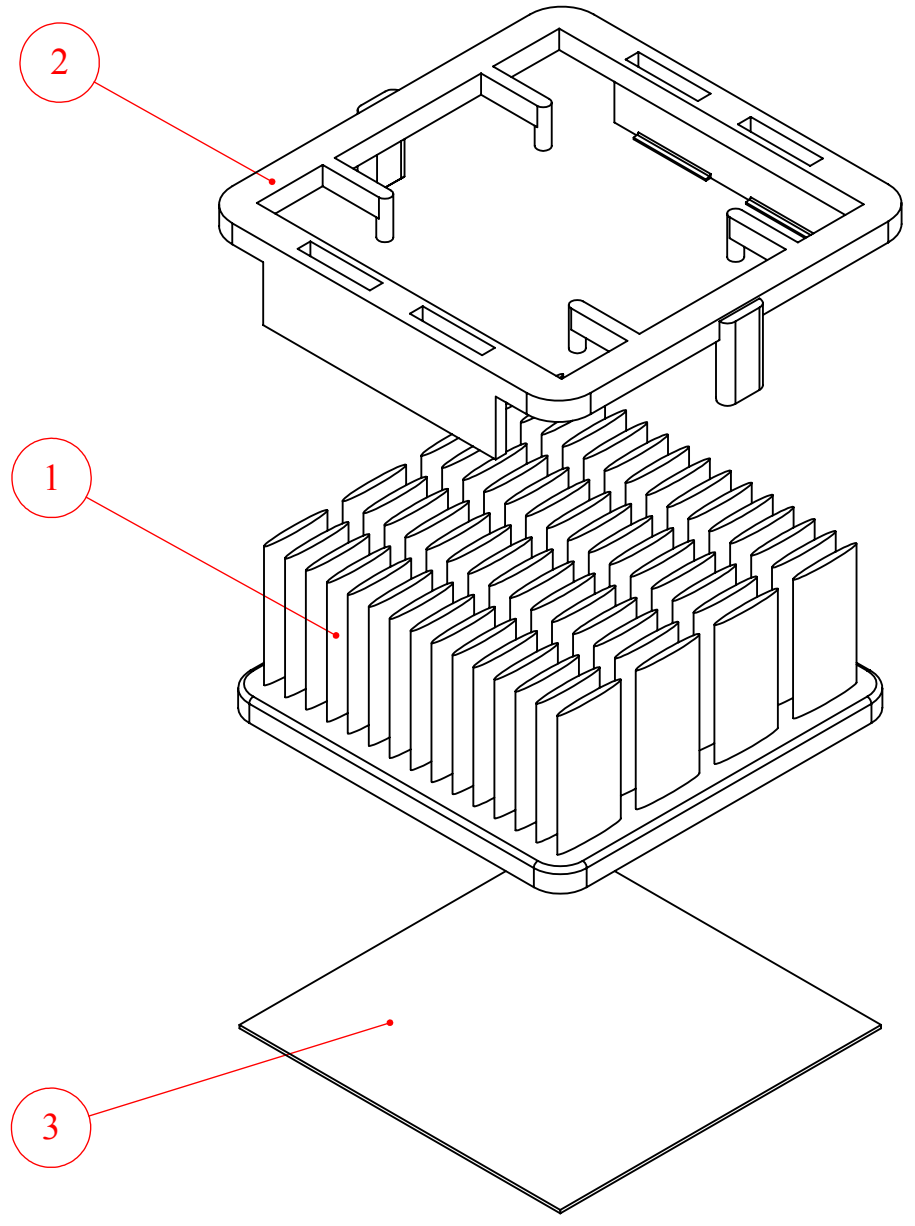

NOTES:

1. SEE TABLE BELOW FOR COMPLETE PART NUMBER WITH OPTIONS.
2. RECOMMENDED KEEP-OUT AREA: 47.5X47.5 MM.
3. COLOR OF CLIP TO BE SELECTED BASED ON CHIP HEIGHT AS ILLUSTRATED BELOW.
4. CLIP FITS MIN. 0.25 MM SOLDER BALL HEIGHT.

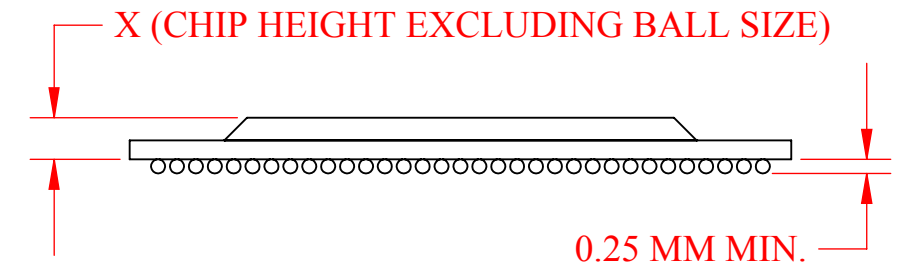

X	CLIP COLOR
3.3±0.3 MM	YELLOW
1.7±0.3 MM	BLUE
0.9±0.3 MM	ORANGE

COMPLETE PART NUMBER WITH OPTIONS				
ROOT	HEIGHT (hh)	BASE	CLIP (c)	PAD
INM42.5001-	15W (14.6 MM)	/2.6 (2.6 MM)	Y (YELLOW)	+T710
	18W (17.6 MM)			
	21W (20.6 MM)		O (ORANGE)	+OTHER
	23W (22.6 MM)			
	28W (27.6 MM)			
33W (32.6 MM)				

EXAMPLE PART NUMBER: INM42.5001-23W/2.6BU+T710

ITEM NO.	PART NUMBER	DESCRIPTION	QTY.
1	INM42.5001-hhW/2.6	ELLIPTICAL HEAT SINK (SEE TABLE ON THE RIGHT FOR HEIGHT CODE hh)	1
2	BCP45-09(42.5)c	42.5 MM EZ-SNAP CLIP (SEE TABLE ON THE RIGHT FOR CLIP CODE c)	1
3	OPTIONAL	THERMAL PAD 40X40 MM OR FULL COVERAGE OF HEAT SINK BASE	1

UNLESS OTHERWISE SPECIFIED DIMENSIONS ARE IN MM TOLERANCES ARE:		CAD GENERATED DRAWING, DO NOT MANUALLY UPDATE		 RADIAN HEATSINKS DIV. OF INTRICAST CO. INC. 2160 WALSH AVE SANTA CLARA, CA - 95050
DECIMALS	ANGLES	APPROVALS	DATE	
X. ±.25	± 1°	DRAWN	9/22/05	42.5 MM ELLIPTICAL HEAT SINK
X.X ±.25		CHECKED	9/23/05	
X.XX ±.10		RESP ENG	9/22/05	
		MFG ENG		
MATERIAL	FINISH	QUAL ENG		
NEXT ASSY	USED ON			SIZE B
APPLICATION	DO NOT SCALE DRAWING			DWG. NO. INM42.5001
SHEET 1 OF 1				REV. C